

HYUNDAI

INSTRUKCJA TECHNICZNA DTR

MODEL:

HCD-M12IU HCU-M120U

HCD-M18IU HCU-M180U

HCD-M24IU HCU-M240U

HCD-M36IU HCU-M360U

HCD-M48IU HCU-M480U

HCD-M55IU HCU-M550U

DUCT UNIT

KLIMATYZATOR KANAŁOWY
TYPU SPLIT

WAŻNA UWAGA:



Przeczytaj uważnie niniejszą instrukcję przed instalacją lub obsługą klimatyzatora Hyundai. Zachowaj tę instrukcję do późniejszego wykorzystania.

Imported / Distributed by AB Klima. Licensed by Hyundai Corporation Holdings, Korea. After-Sales Service Center locations are in Poland. Assembled in P.R.C.

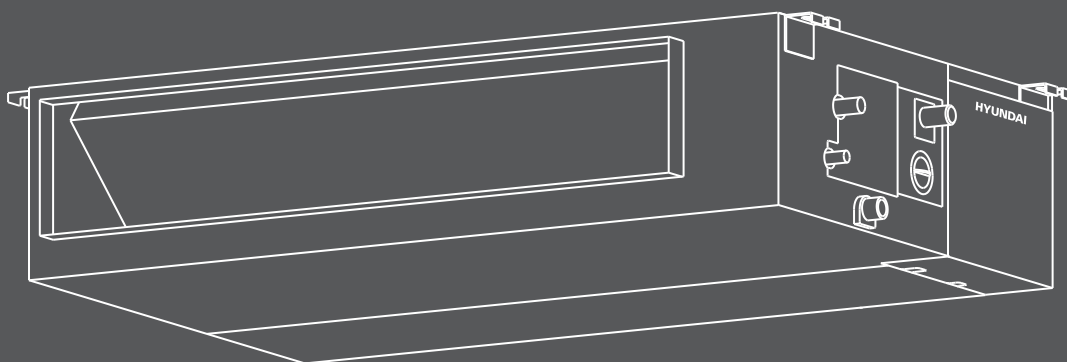

A6 Duct Type

1. Features	28
2. Dimensions	31
3. Service Space	32
4. Wiring Diagrams	33
5. Static Pressure.....	39
6. Electric Characteristics	45
7. Sound Levels	46
8. Accessories.....	47
9. The Specification of Power	48
10. Field Wiring	49

1. Features

1.1 Higher Static Pressure

- As a ducted air conditioner with medium static pressure, it has the widest static pressure range.
- The maximum static pressure reaches 160 Pa



1.2 Slim Design

- The industry Lowest height is designed to be fitted into tight roof spaces.
- *18K unit - 210mm, 24K/36K unit - 249mm, 48K unit -300mm

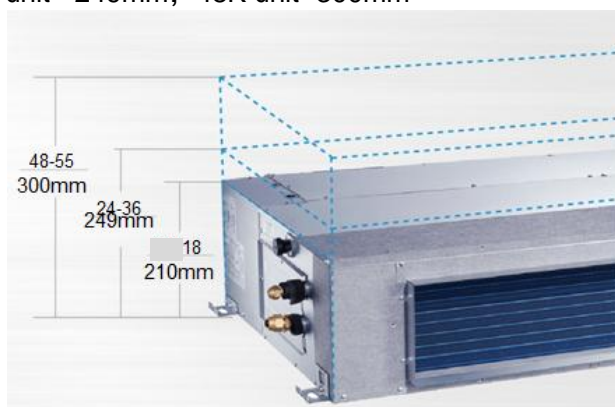

1.3 Constant air volume control

- For ordinary duct, when the static pressure exceeds the expected range, it is fairly difficult even for an experienced installer to calculate and adjust the air volume precisely.
- With constant air volume control technology, the duct will automatically adjust to perfect static pressure and keep constant air volume.

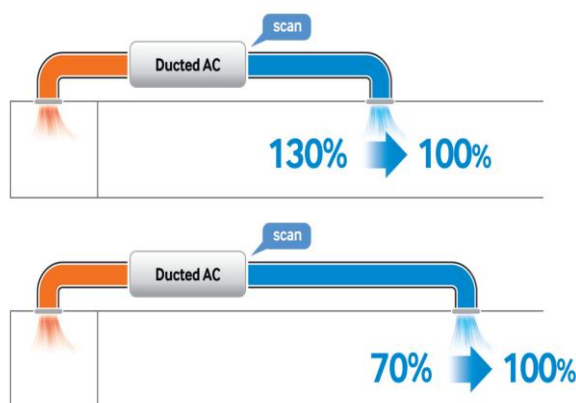

1.4 Flexible Air Intake Way (Bottom side or Rear side)

- The frame size of air inlet in rear and bottom is the same. It's very easy to switch to match different application.

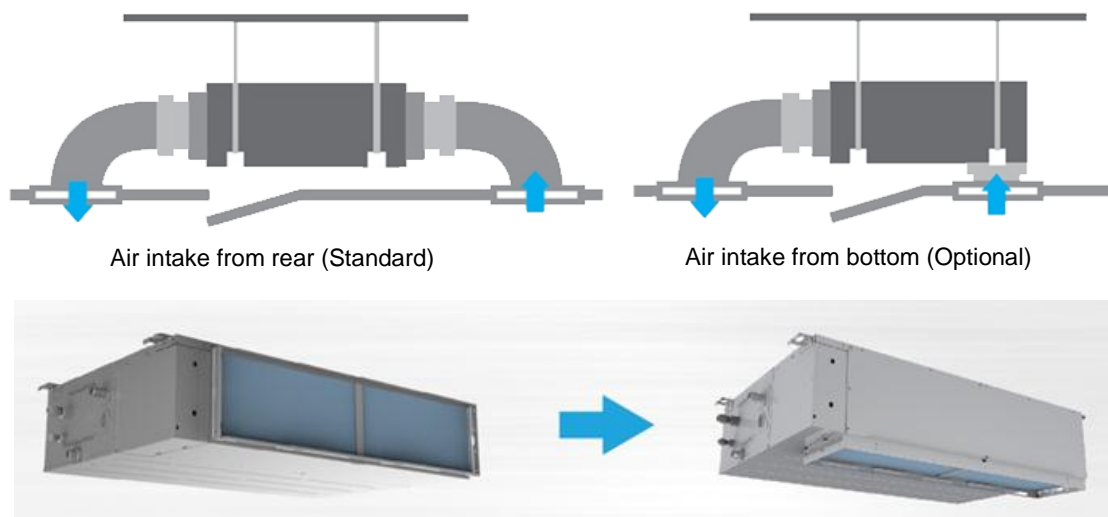

1.5 Communication wire connection

- A6 duct uses two wires without polarity connection way, which almost has no mistake during the installation.



1.6 Easy Clean

- With a larger window design, once the motor and the blower wheels have been detached, heat exchanger and water receiver tray in behind can be seen very clearly. Dust can be easily removed from the inside by vacuum



1.7 Fresh air intake function(Optional)

- Install one duct from the reserved fresh-air intake to outdoor. Continually inhale the fresh air to improve the quality of the indoor air, fulfills air quality more healthy and comfortable.
- A ventilation motor (provided by the installer) can be installed inside the fresh air duct to improve the fresh air volume. There are reserved ports for this motor on main PCB (Standard for 3D inverter units, and only optional for DC inverter 53~160 units).

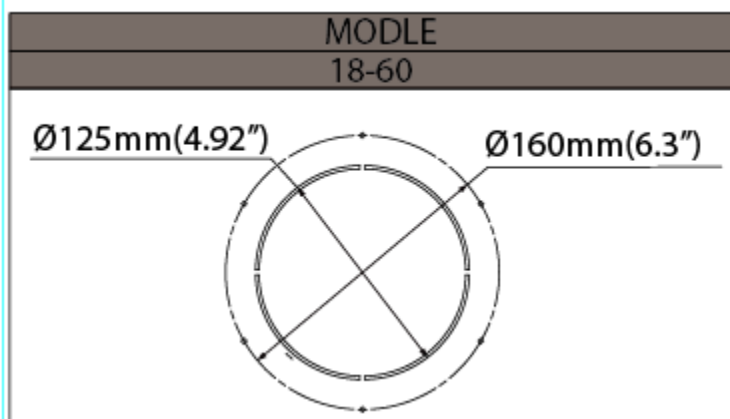

1.8 Built-in drain pump (Optional)

- Built-in drain pump can lift the water to 750mm upmost, which widens the drainage piping range.

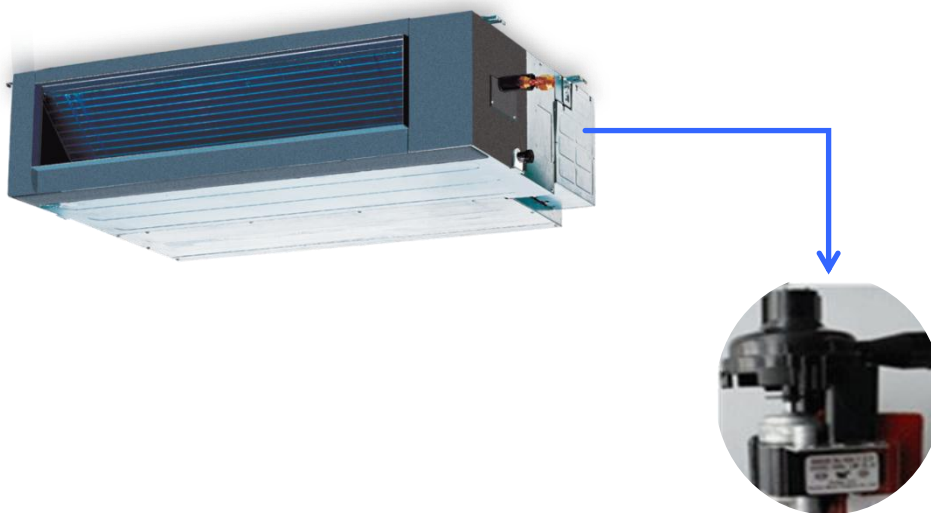
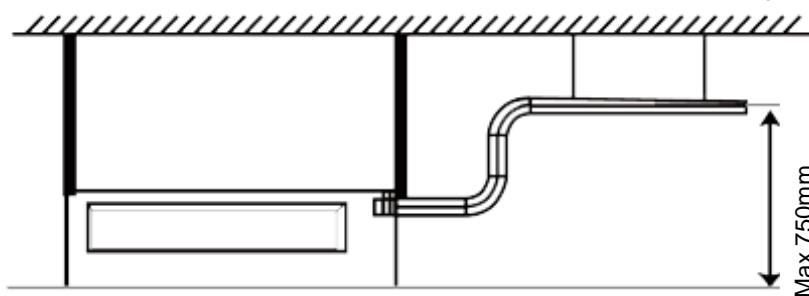

2. Dimensions

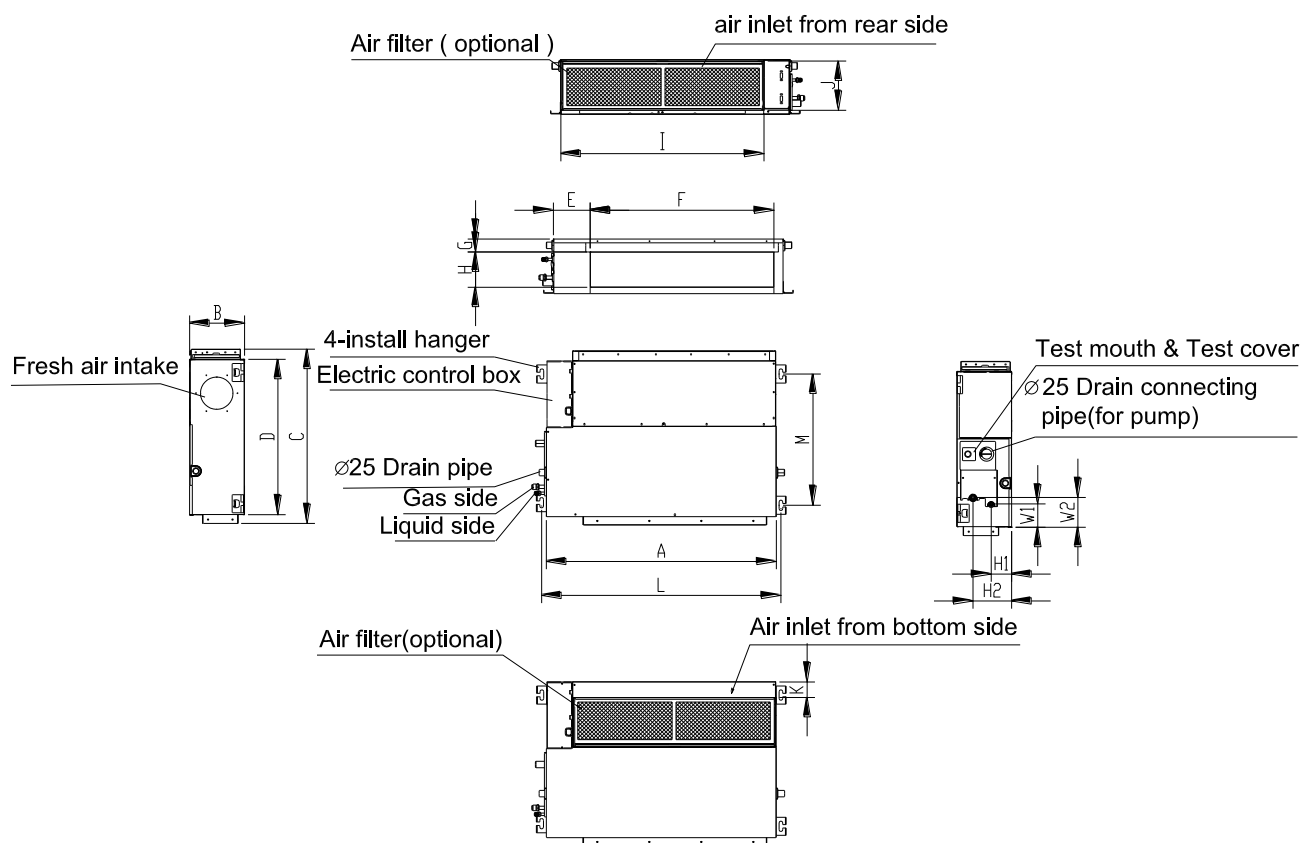

Model (Kbtu/h)	unit	A	B	C	D	E	F	G	H	I	J	K	L	M	H1	H2	W1	W2
12	mm	700	200	506	450	137	537	30	152	599	186	50	741	360	84	140	84	84
	inch	27.6	7.9	19.9	17.7	5.4	21.1	1.2	6.0	23.6	7.3	2.0	29.2	14.2	3.3	5.5	3.3	3.3
18	mm	880	210	674	600	140	706	50	136	782	190	40	920	508	78	148	88	112
	inch	34.65	8.27	26.54	23.62	5.51	27.80	1.97	5.35	30.79	7.48	1.57	36.22	20.00	3.07	5.83	3.46	4.41
24	mm	1100	249	774	700	140	926	50	175	1001	228	5	1140	598	80	150	130	155
	inch	43.31	9.80	30.47	27.56	5.51	36.46	1.97	6.89	39.41	8.98	0.20	44.88	23.54	3.15	5.91	5.12	6.10
30-36	mm	1360	249	774	700	140	1186	50	175	1261	228	5	1400	598	80	150	130	155
	inch	53.54	9.80	30.47	27.56	5.51	46.69	1.97	6.89	49.65	8.98	0.20	55.12	23.54	3.15	5.91	5.12	6.10
42-55	mm	1200	300	874	800	123	1044	50	227	1101	280	5	1240	697	80	150	185	210
	inch	47.24	11.81	34.41	31.5	4.84	41.1	1.97	8.94	43.35	11.02	0.20	48.82	27.44	3.15	5.91	7.28	8.27

3. Service Space

Ensure enough space required for installation and maintenance.

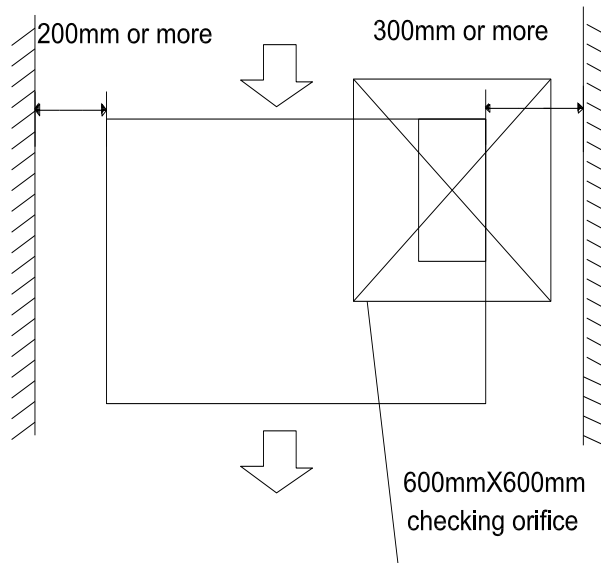

4. Wiring Diagrams

12kBTu/h

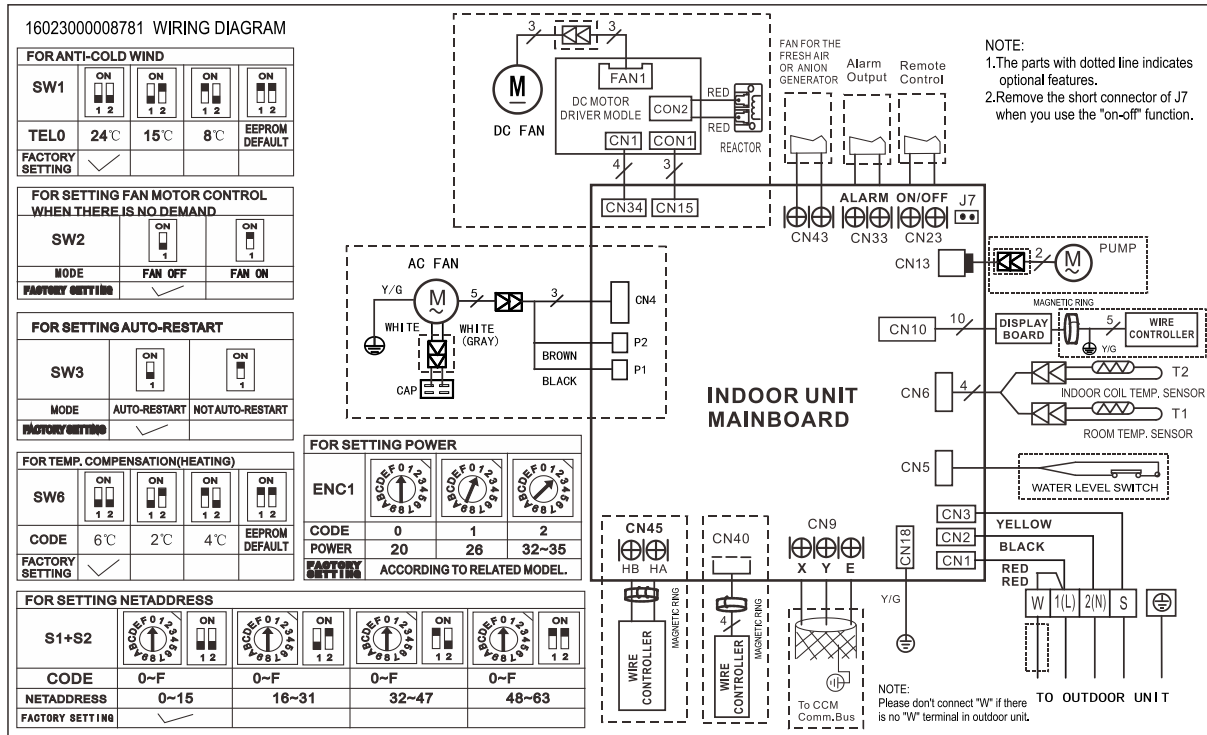

18kBTu/h, 24kBTu/h, 30kBTu/h, 36kBTu/h, 42kBTu/h, 48kBTu/h, 55kBTu/h

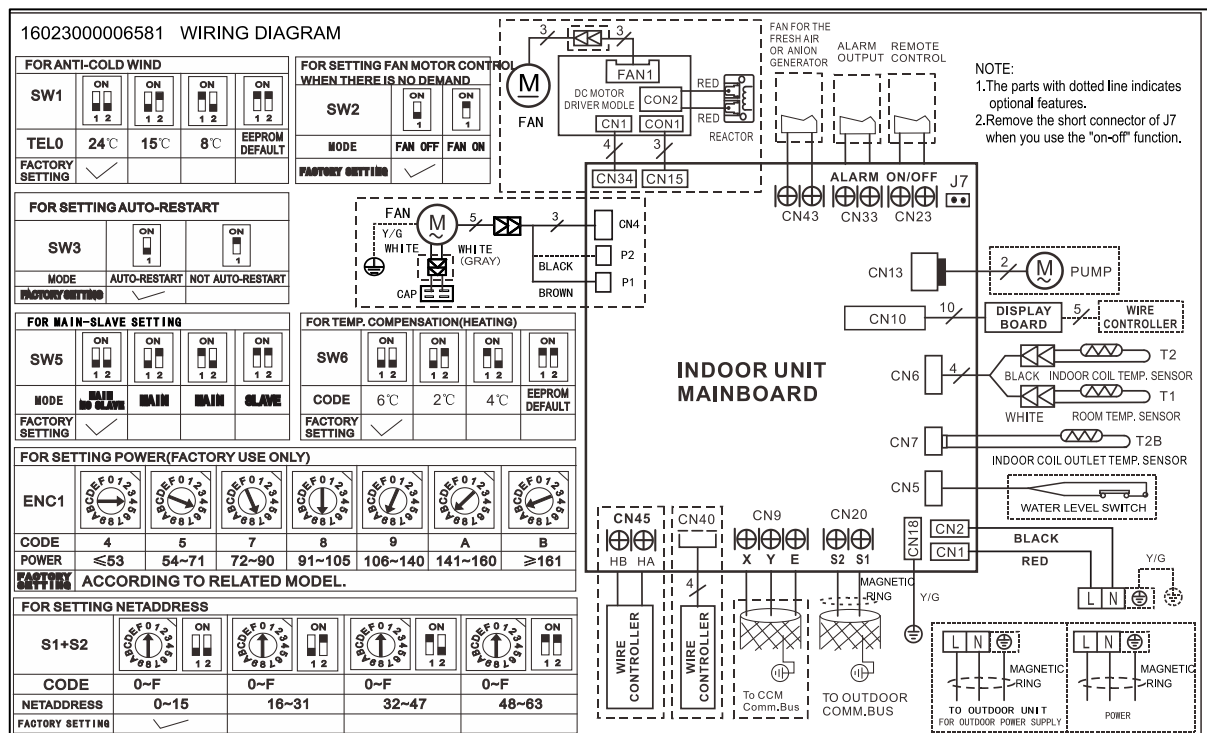

4.1 Some connectors introduce:

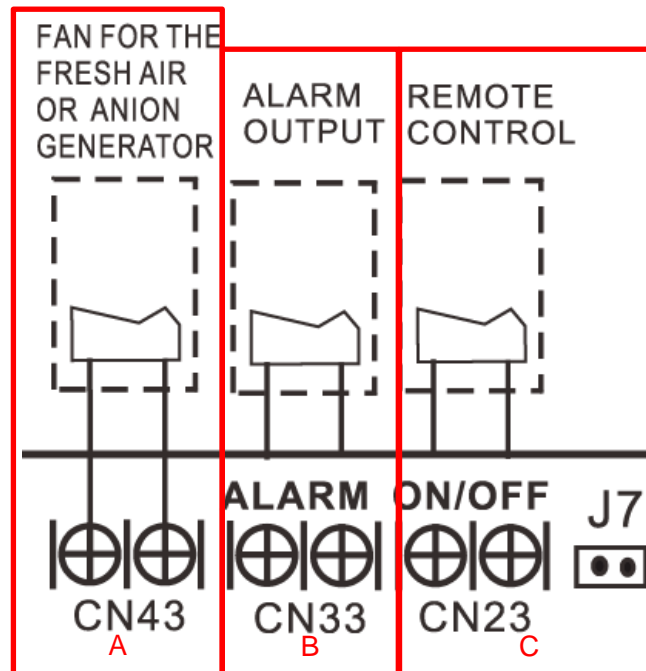

A. For new fresh motor terminal port (also for Anion generator) CN43:

1. Connect the fan motor to the port, no need care L/N of the motor;
2. The output voltage is the power supply;
3. The fresh motor cannot exceed 200W or 1A, follow the smaller one;
4. The new fresh motor will be worked when the indoor fan motor work; when the indoor fan motor stops, the new fresh motor would be stopped;
5. When the unit enter force cooling mode or capacity testing mode, the fresh motor isn't work.

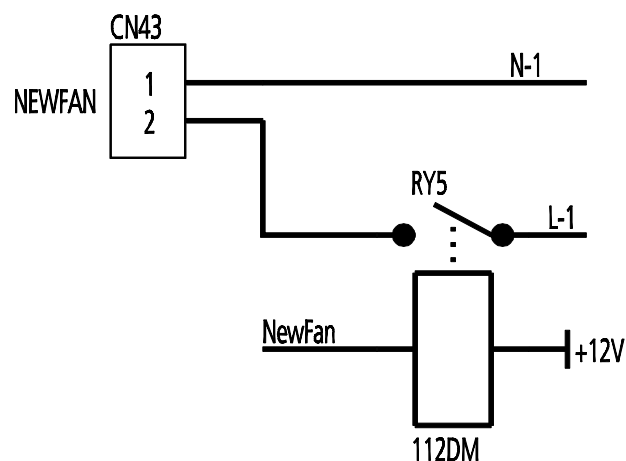

B For ALARM terminal port CN33

1. Provide the terminal port to connect ALARM, but no voltage of the terminal port, the power from the ALARM system (not from the unit)
2. Although design voltage can support higher voltage, but we strongly ask you connect the power less than 24V, current less than 0.5A.
3. When the unit occurs the problem, the relay would be closed, then ALARM works.

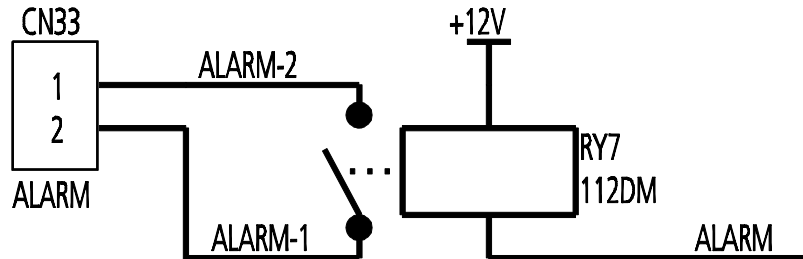

C. For remote control (ON-OFF) terminal port CN23 and short connector of J7

1. Remove the short connector of J7 when you use ON-OFF function;
 2. When remote switch off (OPEN), the unit would be off;
 3. When remote switch on (CLOSE), the unit would be on;
 4. When close/open the remote switch, the unit would be responded the demand within 2 seconds;
 5. When the remote switch on. You can use remote controller/wire controller to select the mode what you want; when the remote switch off, the unit would not respond the demand from remote controller/wire controller.
- When the remote switch off, but the remote controller / wire controller are on, CP code would be shown on the display board.
6. The voltage of the port is 12V DC, design Max. current is 5mA.

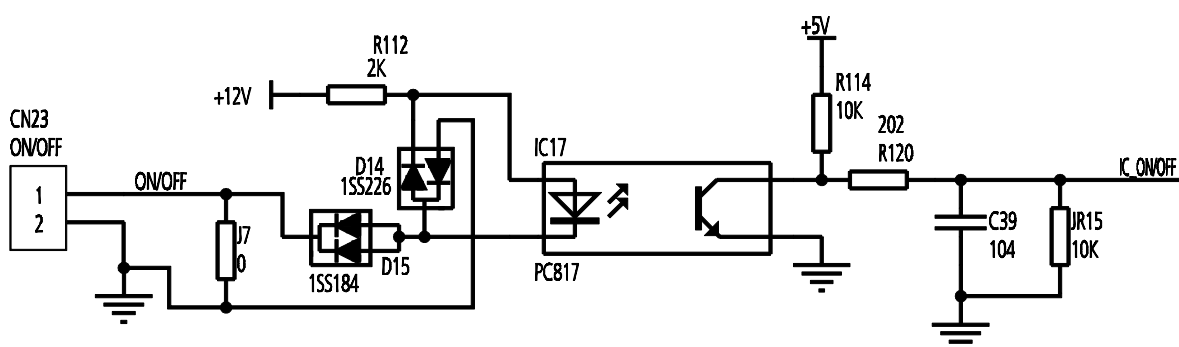

4.2 Micro-Switch Introduce:

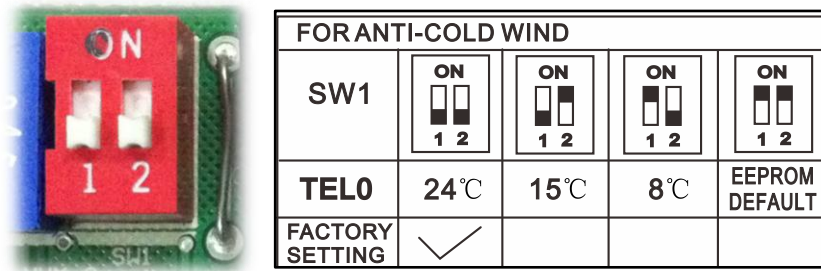

A. Micro-switch SW1 is for selection of indoor fan stop temperature (TELO) when it is in anti-cold wind action in heating mode.

Range: 24°C, 15°C, 8°C, according to EEROM setting (reserved for special customizing).

For 12K:

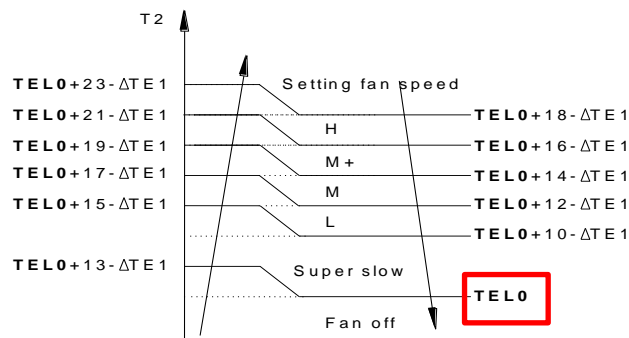

For 18K~55K:

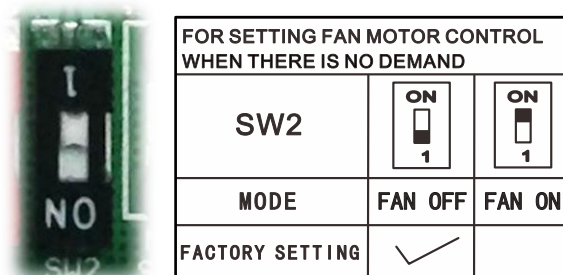
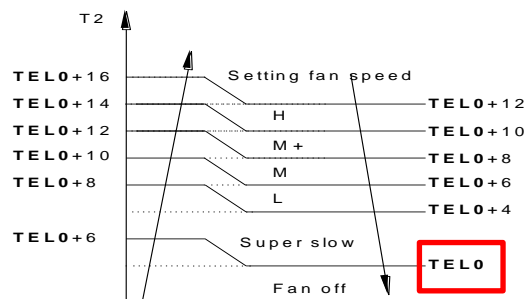

B. Micro-switch SW2 is for selection of indoor FAN ACTION if room temperature reaches the setpoint and the compressor stops.

Range: OFF (in 127s), Keep running.



FOR SETTING AUTO-RESTART		
SW3		
MODE	AUTO-RESTART	NOT AUTO-RESTART
FACTORY SETTING	<input checked="" type="checkbox"/>	

C. Micro-switch SW3 is for selection of auto-restart function.
 Range: Active, inactive

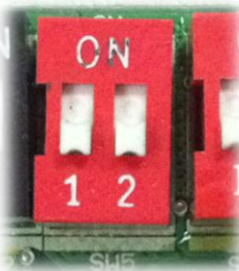

FOR MAIN-SLAVE SETTING				
SW5				
MODE	MAIN NO SLAVE	MAIN	MAIN	SLAVE
FACTORY SETTING	<input checked="" type="checkbox"/>			

D. Micro-switch SW5 is for setting the master or slave unit when the unit is in twin connection.
 Range: Master no slave (Normal 1 drive 1 connection), Master (2 positions without difference), Slave

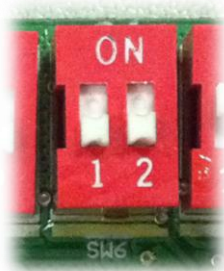

FOR TEMP. COMPENSATION(HEATING)				
SW6				
CODE	6°C	2°C	4°C	EEPROM DEFAULT
FACTORY SETTING	<input checked="" type="checkbox"/>			

E. Micro-switch SW6 is for selection of temperature compensation in heating mode. This helps to reduce the real temperature difference between ceiling and floor so that the unit could run properly. If the height of installation is lower, smaller value could be chosen.
 Range: 6°C, 4°C, 2°C, E function (reserved for special customizing)

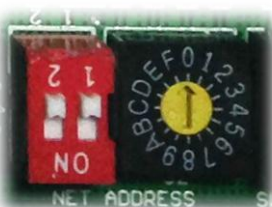

FOR SETTING NETADDRESS				
S1+S2				
CODE	0~F	0~F	0~F	0~F
NETADDRESS	0~15	16~31	32~47	48~63
FACTORY SETTING	<input checked="" type="checkbox"/>			

F. Micro-switch S1 and dial-switch S2 are for address setting when you want to control this unit by a central controller.
 Range: 00-63

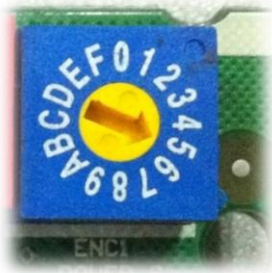

FOR SETTING POWER(FACTORY USE ONLY)							
ENC1							
CODE	4	5	7	8	9	A	B
POWER	≤53	54~71	72~90	91~105	106~140	141~160	≥161
FACTORY SETTING	ACCORDING TO RELATED MODEL.						

G. Dial-switch ENC1: The indoor PCB is universal designed for whole series units from 18K to 55K. This ENC1 setting will tell the main program what size the unit is.

NOTE: Usually there is glue on it because the switch position cannot be changed at random unless you want to use this PCB as a spare part to use in another unit. Then you have to select the right position to match the size of the unit.

“53” means 5.3kW (18K), “105” means 10.5kW(36K), and so on.

5. Static Pressure

12k

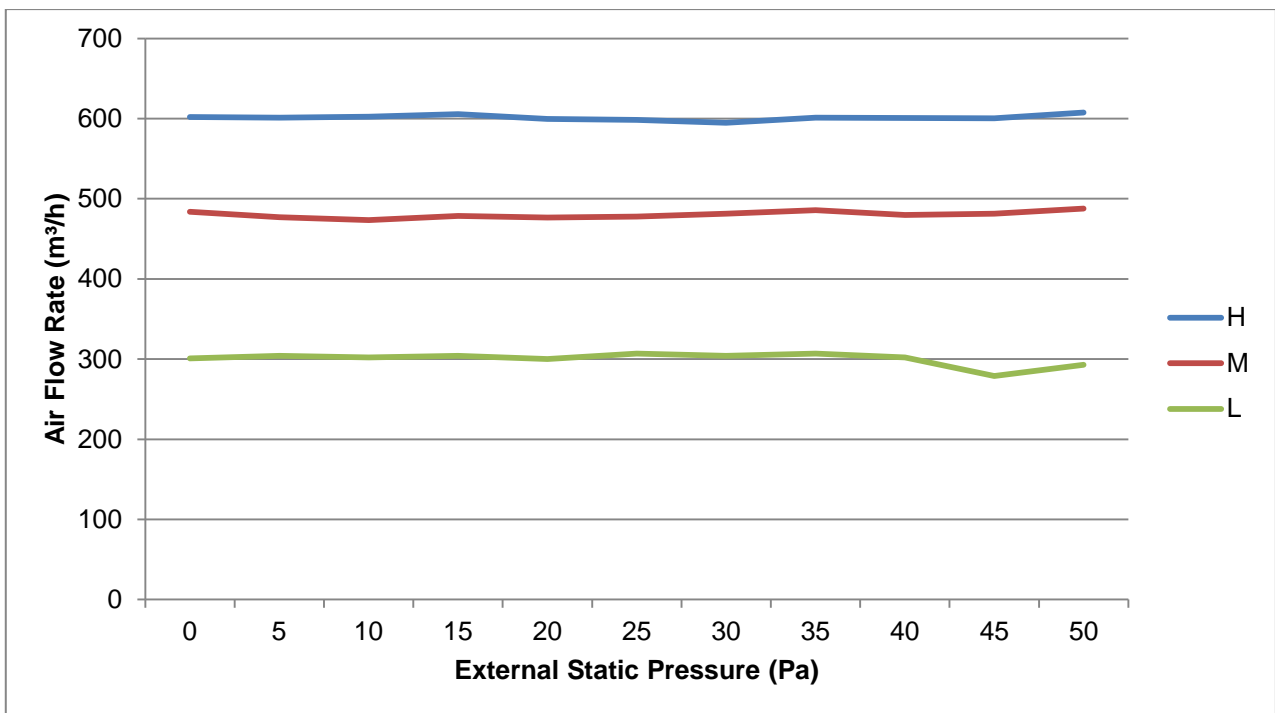
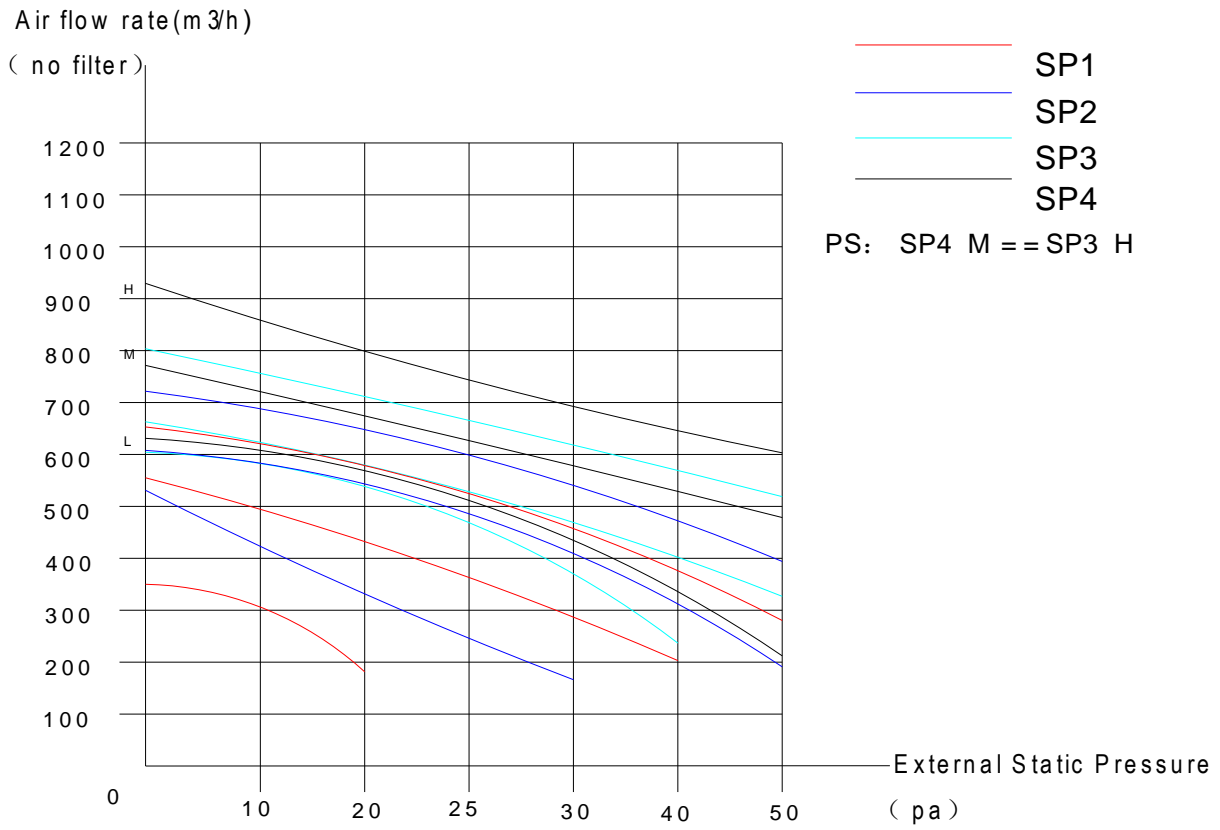

18k

Air flow rate (m³/h)
(no filter)

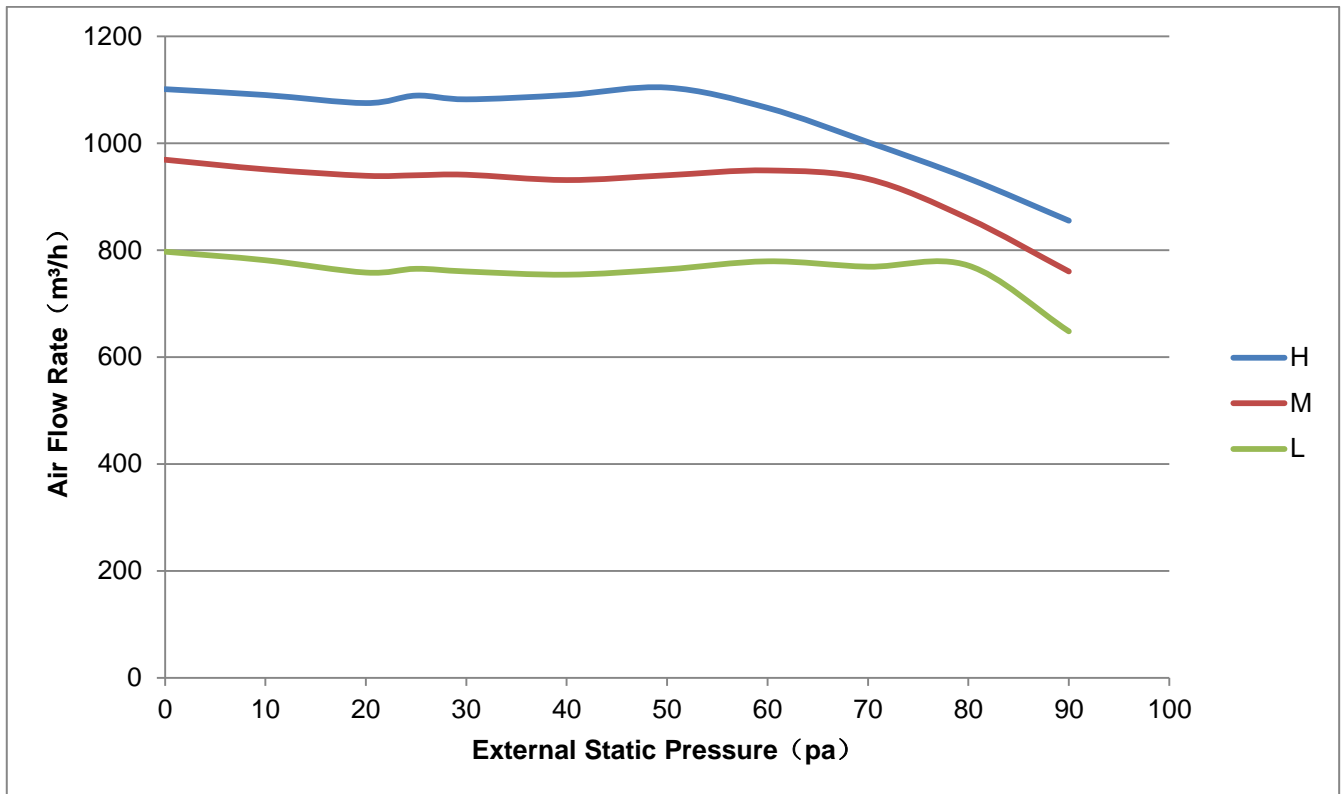
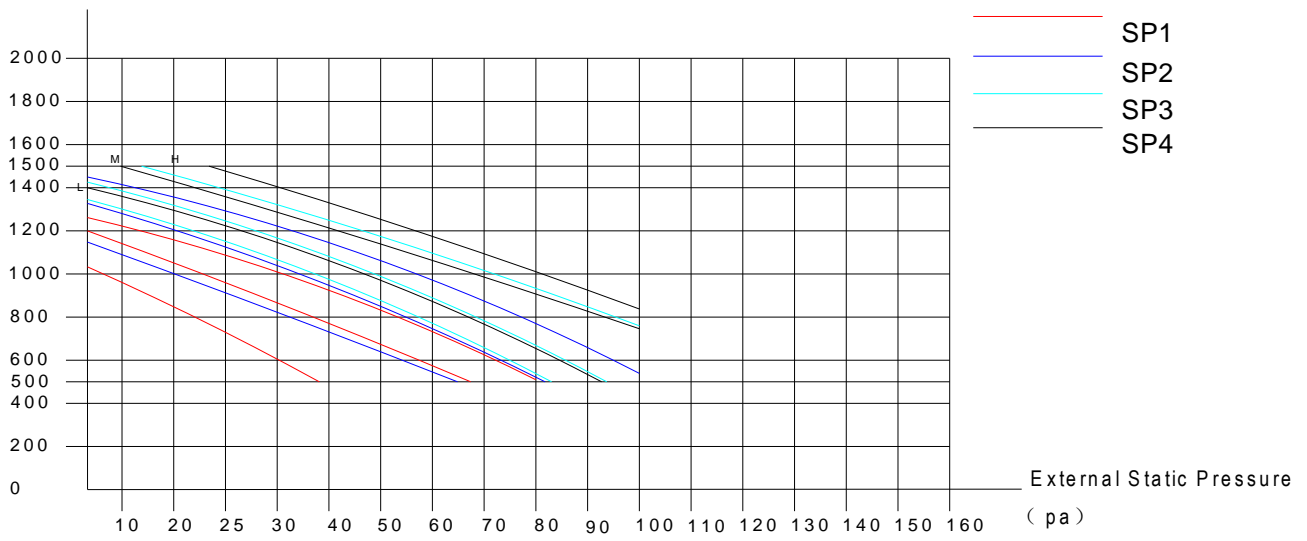

24k

Air flow rate(m³/h)
(no filter)

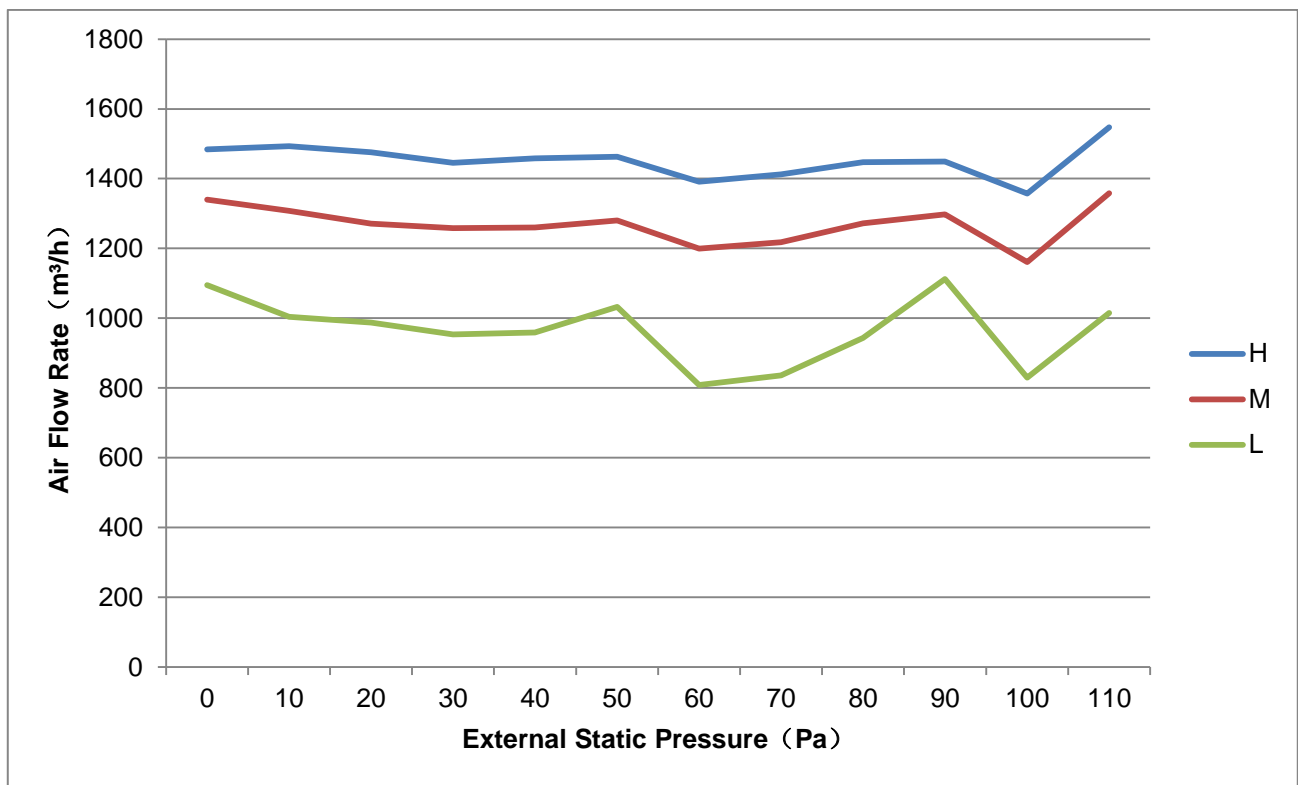
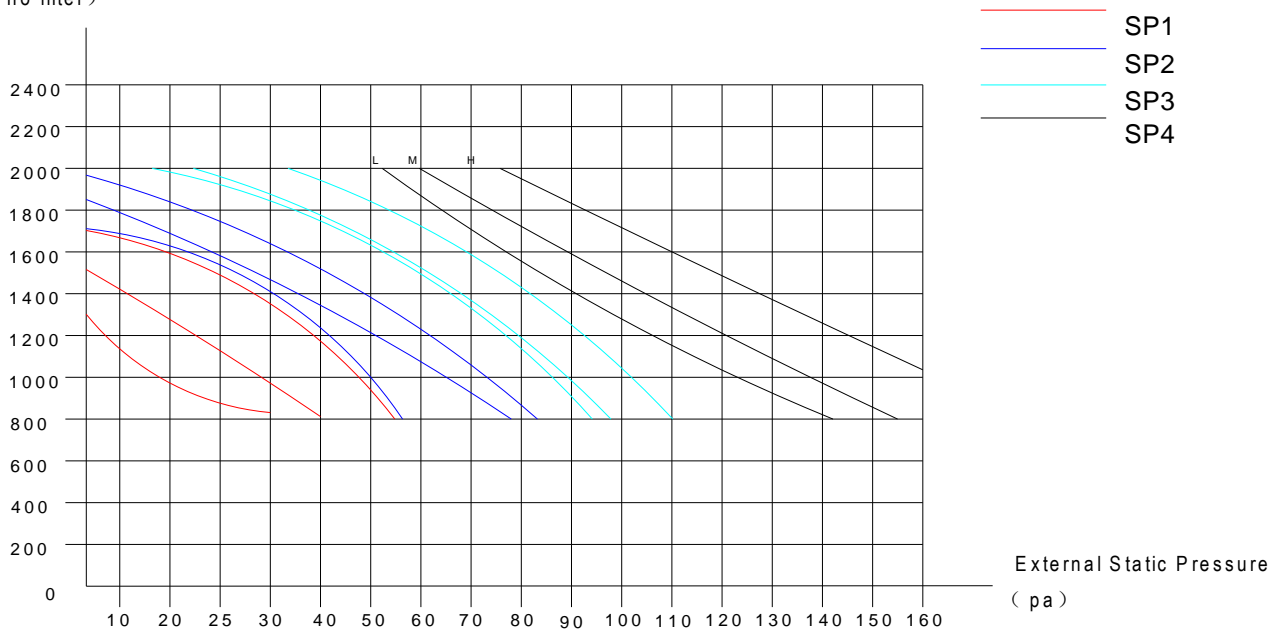

30k/36k

Air flow rate(m³/h)
(no filter)

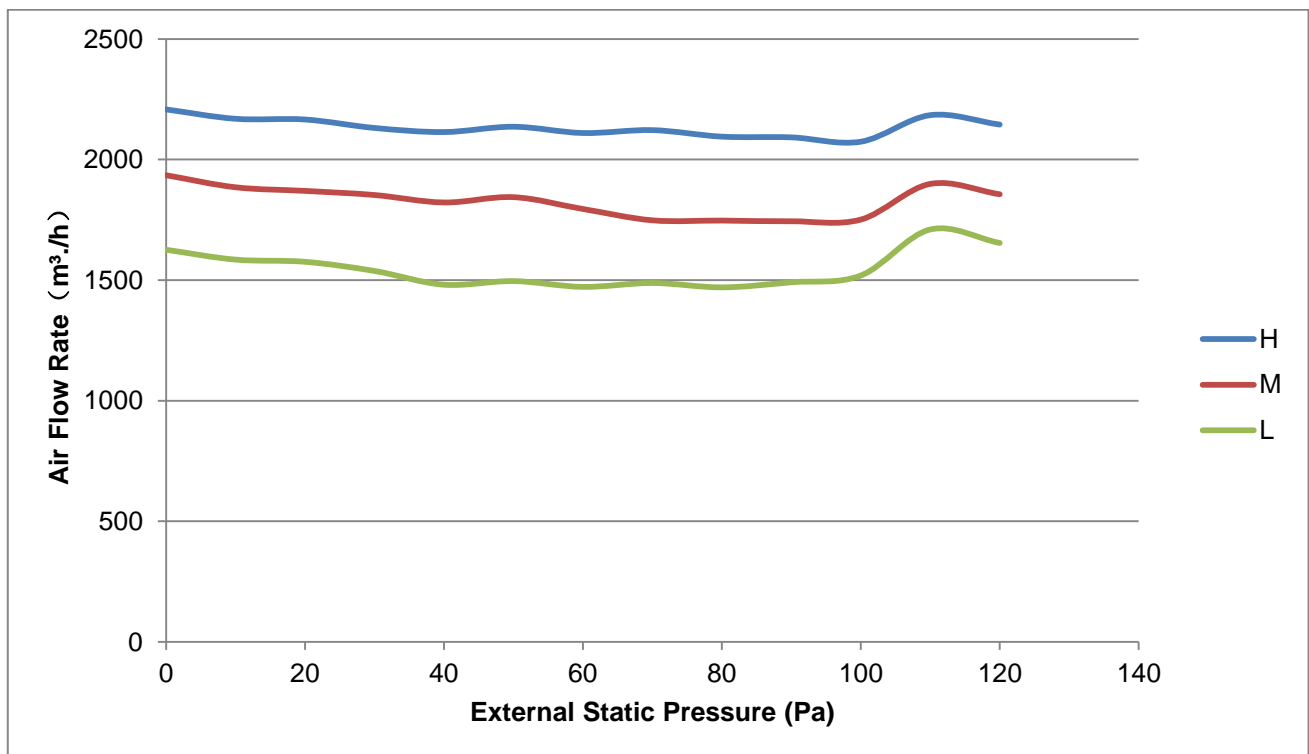
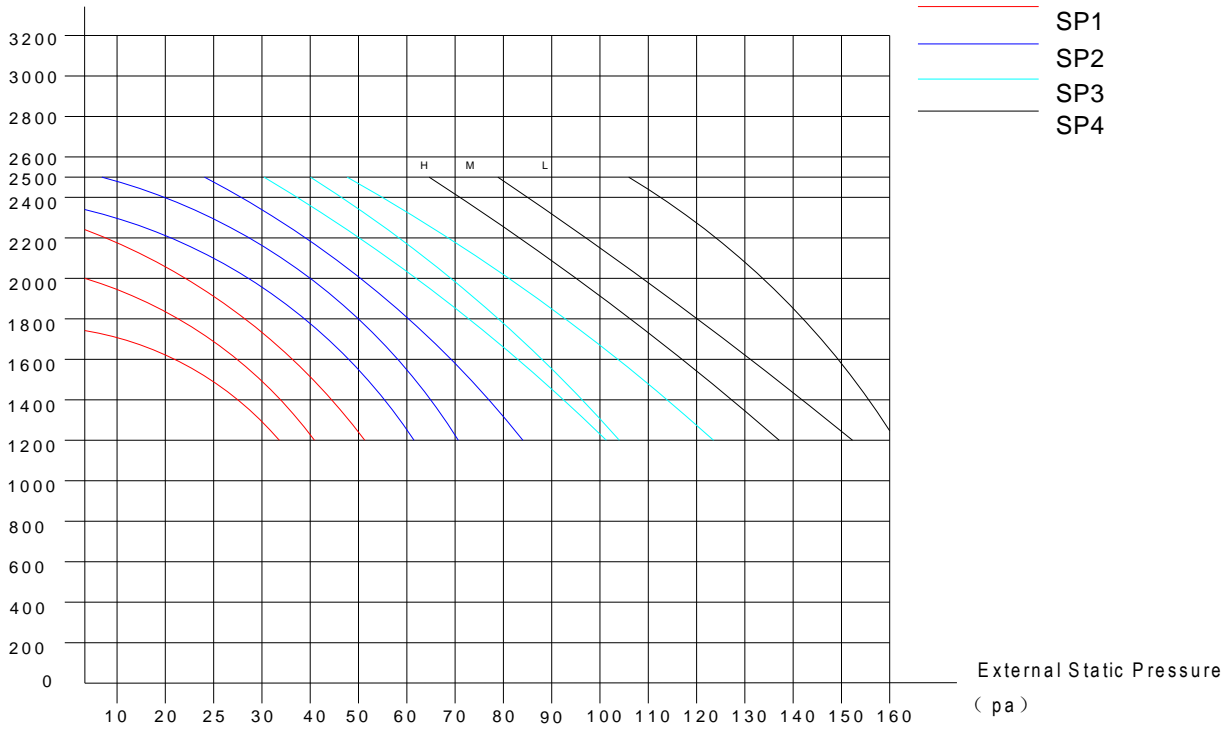

42k/48k

Air flow rate(m³/h)
(no filter)

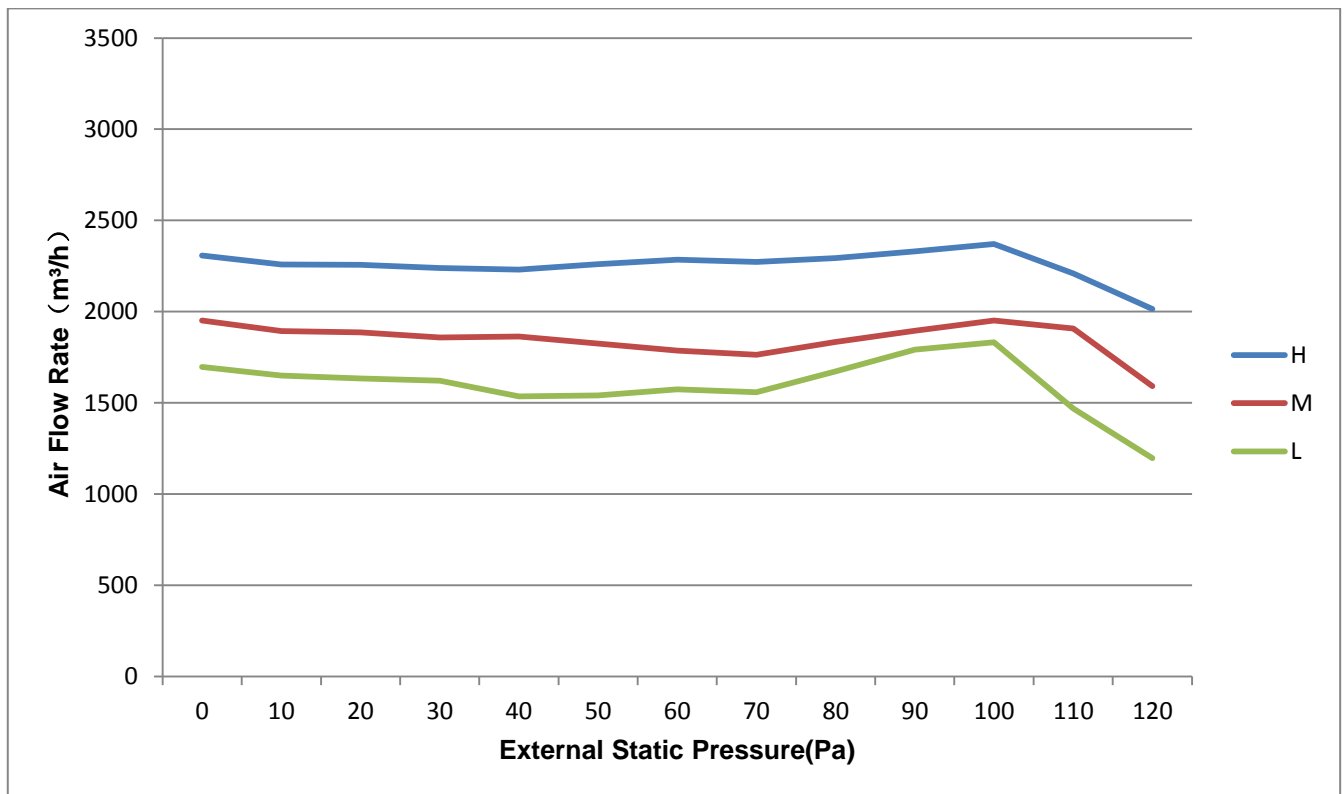
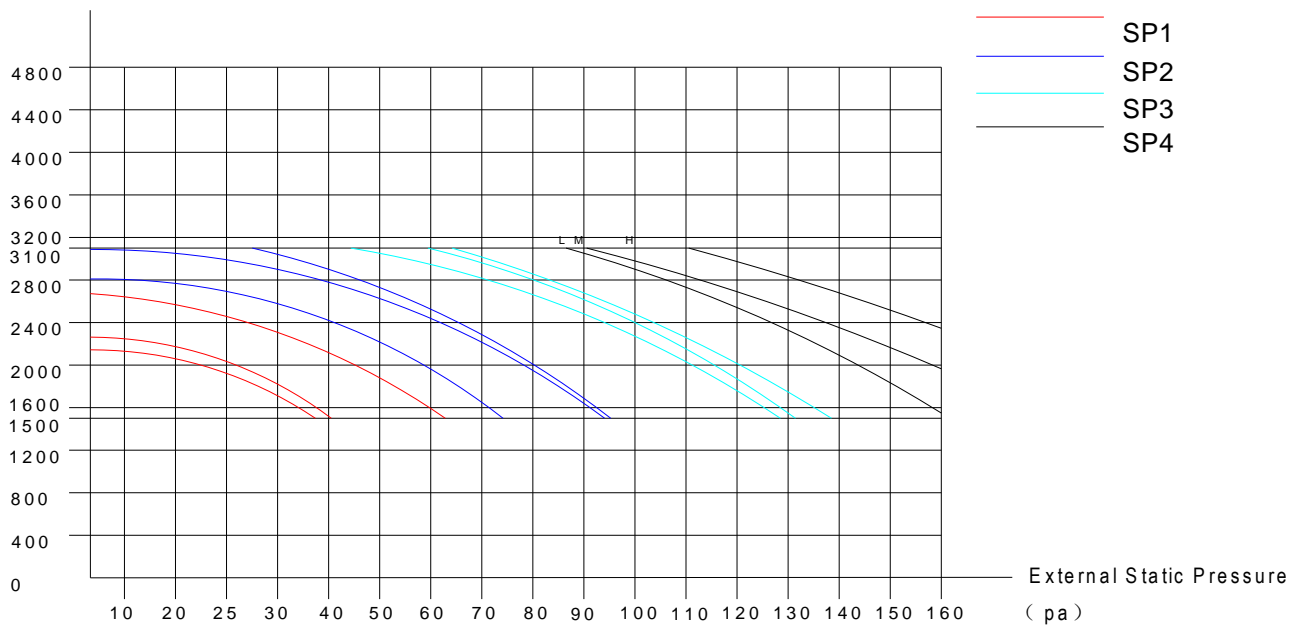

55k

Air flow rate(m³/h)
(no filter)

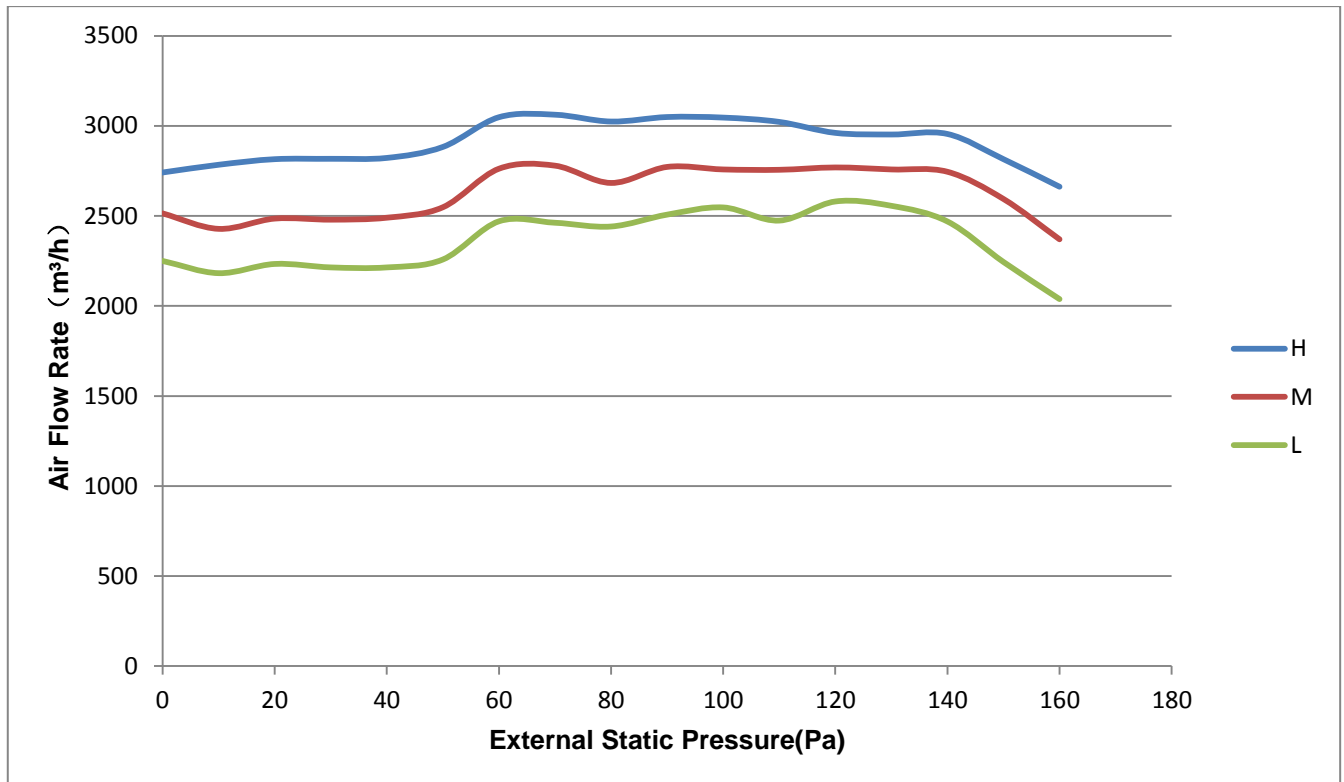
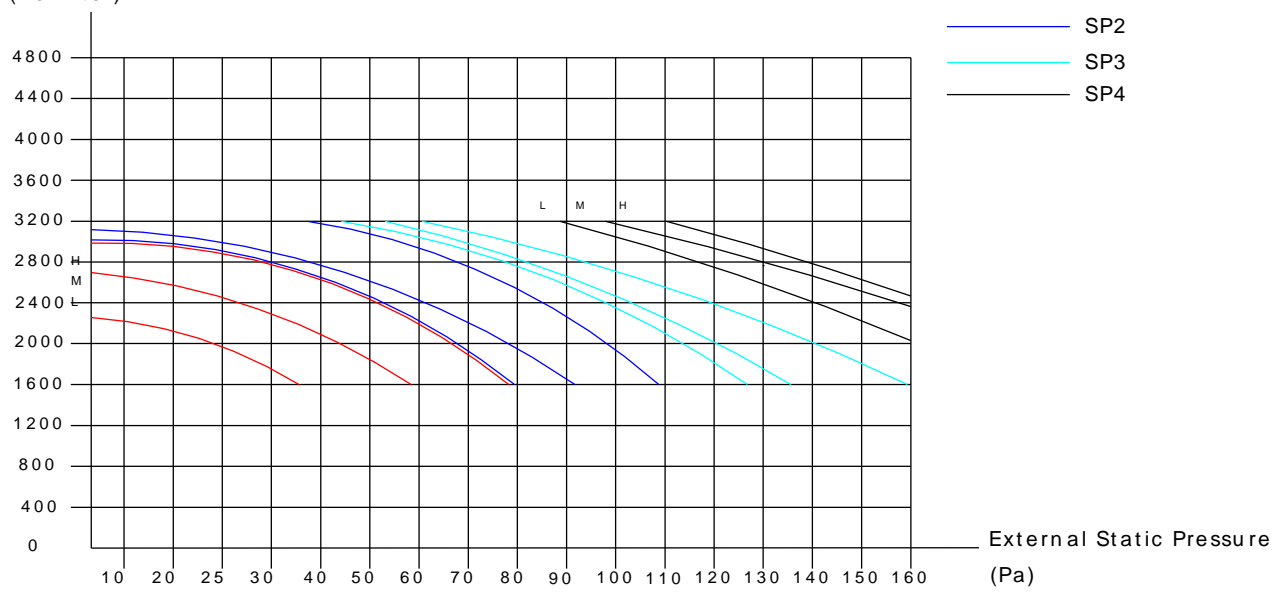

6. Electric Characteristics

Model	Indoor Unit				Power Supply
	Hz	Voltage	Min.	Max.	MFA
12kBtu/h	50	220-240V	198V	254V	/
18kBtu/h	50	220-240V	198V	254V	/
24kBtu/h	50	220-240V	198V	254V	/
30kBtu/h	50	220-240V	198V	254V	/
36kBtu/h	50	220-240V	198V	254V	/
42kBtu/h	50	220-240V	198V	254V	/
48kBtu/h	50	220-240V	198V	254V	/
55kBtu/h	50	220-240V	198V	254V	/

Note:





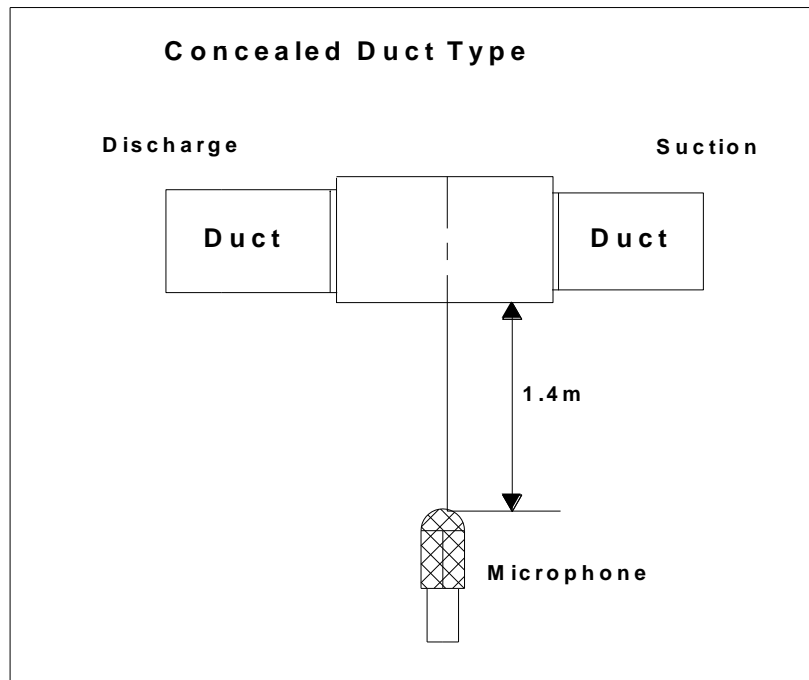



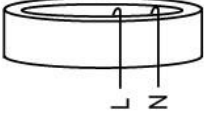

MFA: Max. Fuse Amps. (A)

7. Sound Levels



Model	Sound Power dB(A)	Noise level dB(A)		
		H	M	L
12kBtu/h	56	35	30.5	26
18kBtu/h	61	43.5	42.5	40.5
24kBtu/h	62	41.5	39.5	37.5
30kBtu/h	65	45.5	43	40
36kBtu/h	63	44.5	41.5	38.5
36kBtu/h	63	50	43	40
42kBtu/h	71	53.5	51	49
48kBtu/h	67	50.5	49.5	48
55kBtu/h	71	54	52	50.5

8. Accessories

	Name	Shape	Quantity
Tubing & Fittings	Soundproof / insulation sheath		2
	Drainpipe Fittings (for cooling & heating)	Drain joint	
	Seal ring		1
EMC & It's Fitting (for some models)	Magnetic ring (twist the electric wires L and N around the magnetic ring to five circles)		1
Wired controller & Its Frame	Wired controller		1
	Owner' s manual of wired controller		1
	Wired controller installation manual		1
Others	Owner' s manual		1
	Installation manual		1
	Connecting wire for display (2m)		1(on some models)
	Cord protection rubber ring		1(on some models)

9. The Specification of Power

Model(kBtu/h)		12	18~24	30	36
POWER	Phase	1-phase	1-phase	1-phase	1-phase
	Frequency and Voltage	220-240V, 50Hz	220-240V, 50Hz	220-240V, 50Hz	220-240V, 50Hz
	POWER WIRING (mm ²)	3×2.5	3×2.5(3×4.0 with auxiliary electric heater)	3×2.5(3×4.0 with auxiliary electric heater)	3×4.0(3×6.0 with auxiliary electric heater)
CIRCUIT BREAKER/Fuse (A)		25/20	25/20	40/30	40/30
Indoor/Outdoor Connecting Wiring (Weak Electric Signal) (mm ²)		—————	2×0.2	2×0.2	2×0.2
Indoor/Outdoor Connecting Wiring (Strong Electric Signal) (mm ²)		4×1.0(4×2.5 with auxiliary electric heater)	3×1.0(3×2.5 with auxiliary electric heater)	3×1.0(3×2.5 with auxiliary electric heater)	3×1.0(3×2.5 with auxiliary electric heater)

Model(kBtu/h)		42	36	48~60
POWER	Phase	1-phase	3-phase	3-phase
	Frequency and Voltage	220-240V, 50Hz	380-415V, 50Hz	380-415V, 50Hz
	POWER WIRING (mm ²)	3×4.0(3×6.0 with auxiliary electric heater)	5×2.5(5×4.0 with auxiliary electric heater)	5×2.5(5×4.0 with auxiliary electric heater)
CIRCUIT BREAKER/Fuse (A)		50/40	32/25	40/30
Indoor/Outdoor Connecting Wiring (Weak Electric Signal) (mm ²)		2×0.2	2×0.2	2×0.2
Indoor/Outdoor Connecting Wiring (Strong Electric Signal) (mm ²)		3×1.0(3×2.5 with auxiliary electric heater)	3×1.0(3×2.5 with auxiliary electric heater)	3×1.0(3×2.5 with auxiliary electric heater)

10. Field Wiring

12k

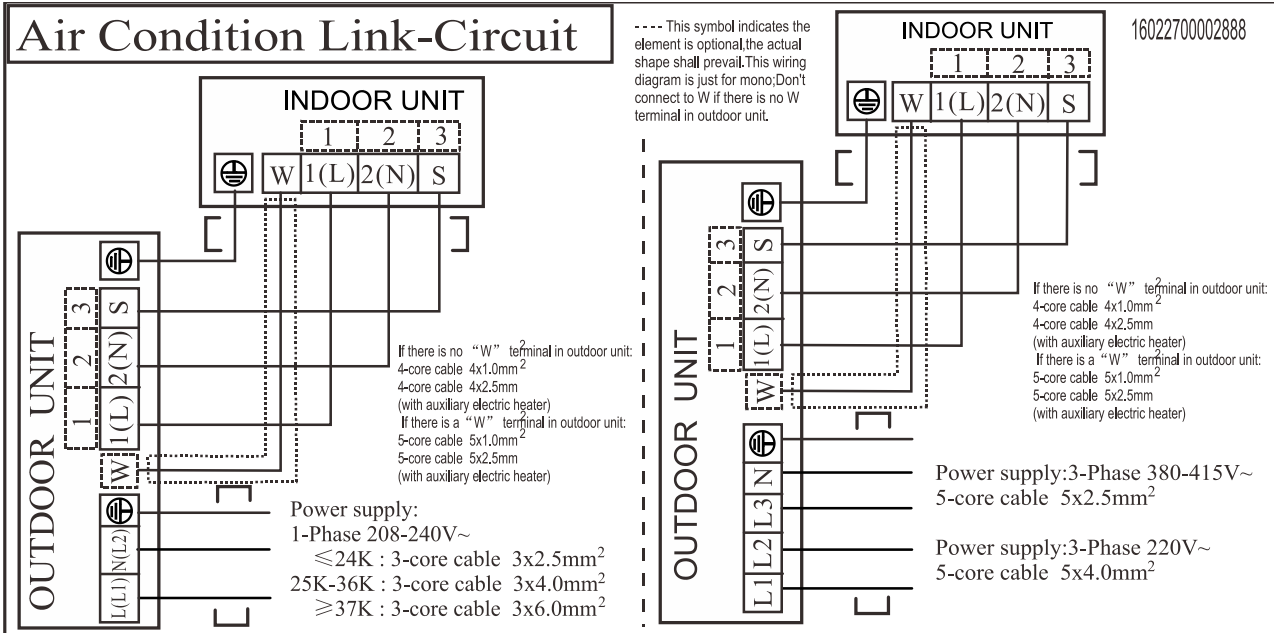

18k~55k

